

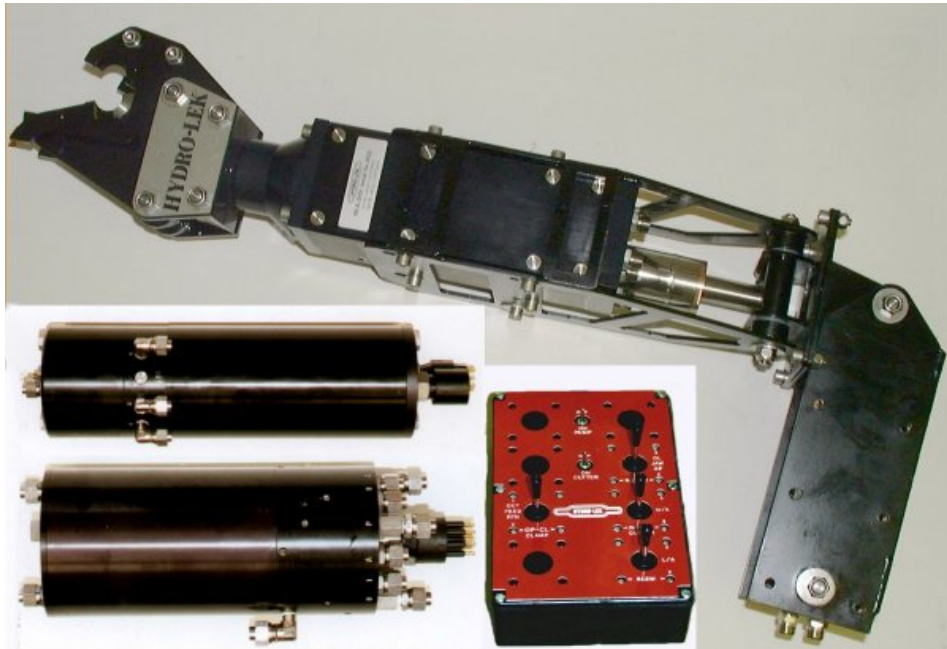

HYDRO-LEK

REMOTE HANDLING SPECIALISTS



Gauntlet Plus System:

GAUNTLET Plus is a complete manipulator system, which has been designed to enhance the working capability of the smaller professional ROV's to increase their operating and earning potential! The basic system can be expanded into a dual arm system or have a disc cutter fitted for wire cutting.

MAIN FEATURES:-

2000 metres working depth; 16Kg weight in water; 40 Nm torque continuous rotate jaw; unique 19mm rope cutter/jaw mechanism; 6mm thick stainless steel jaws; 24 channel telemetry control system; 140 BAR pump output; lift capacity 20Kg; 4 way valve pack; supplied complete with hydraulic hose, fittings, compensator and oil fill pump.

Specification:

Comprises of

**HLK-MB 4 Arm
HLK-7020 Valve Pack
HLK-9020 Power Pack
Telemetry Control System
Hose and Hydraulic Fittings
316 SS
HE 30 Hard anodised aluminium**

Material

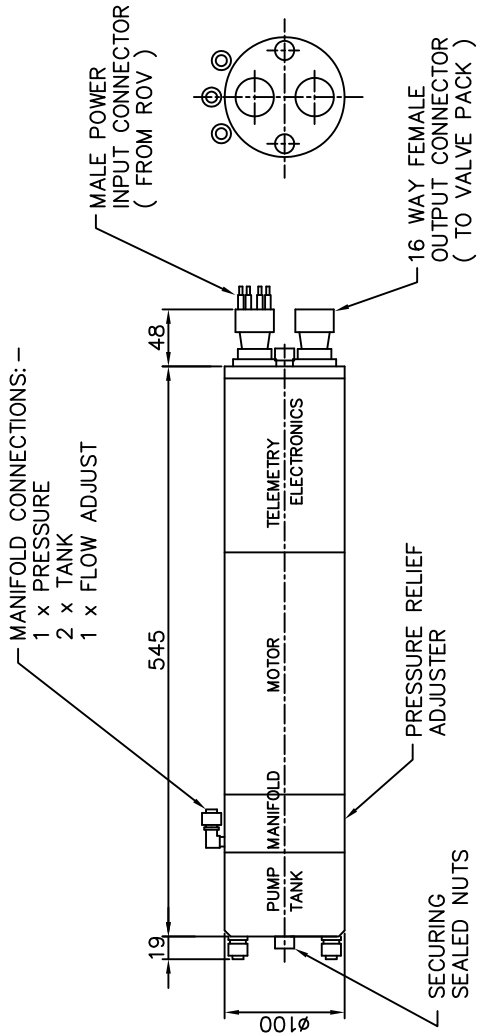

HLK-90200 POWER PACK

POWER INPUT PUMP ONLY (1.8A max.) 240V AC / DC
 MAX. WORKING PRESS. 170 BAR AT 0.5L / MIN.
 WEIGHT IN AIR 140 BAR
 WEIGHT IN WATER 6 KG
 PORTS 4 KG
 MATERIALS: - 1/8" NPT
 HE 30 HARD ANODISED ALUMINIUM

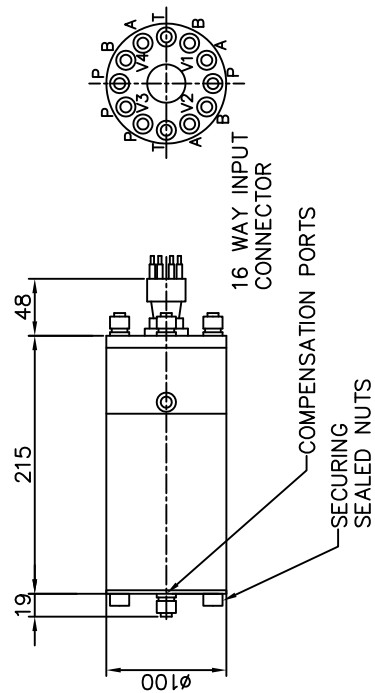

HLK-7020 VALVE PACK

FUNCTION 4-WAY SOLENOID VALVES
 VOLTAGE 24V DC
 MAX. WORKING PRESSURE 210 BAR
 WEIGHT IN AIR 4 KG
 WEIGHT IN WATER 2.5 KG
 PORTS 7/16" SAE
 MATERIALS: - HE 30 HARD ANODISED ALUMINIUM

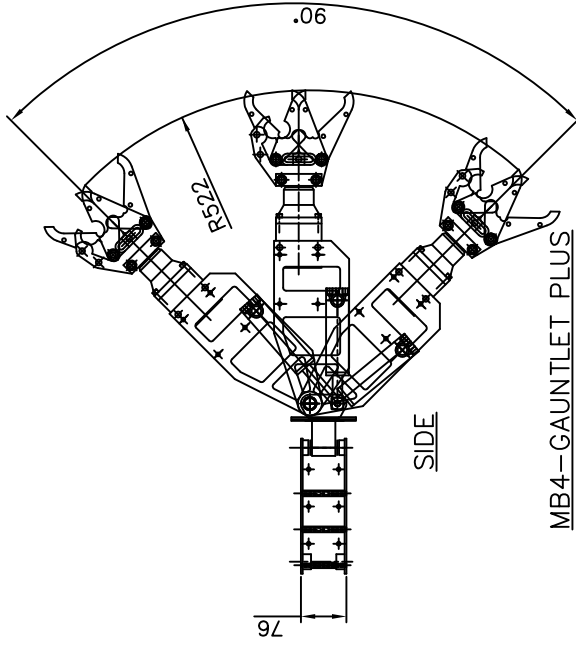
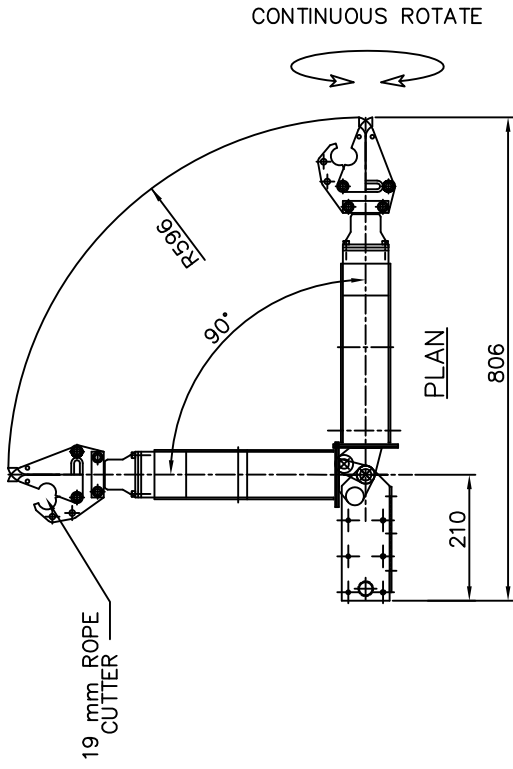

MB4-GAUNTLET PLUS

ROTATE 360° CONTINUOUS
 TORQUE AT 140 BAR 40Nm
 LIFT AT 140 BAR 50 KG
 WEIGHT IN AIR 17.2 KG
 WEIGHT IN WATER 12.0 KG
 MATERIALS: - 316 ST. STEEL/
 HE30 HARD ANODISED ALUMINIUM

HYDRO-LEK LTD.	MB4-GAUNTLET PLUS
ISS. DATE: -	MAT: -
CHKD BY: -	REV. NO: - 1
DRAWN BY: - JW 15/8/00	DRG. NO: -CMR 4200GAU/DATA
	C.M. INNOVATIONS LTD.