



# HYDRO-LEK

## REMOTE HANDLING SPECIALISTS



### HLK-90150 Power Pack:

The HLK-90150 Power Pack is a 3-phase 4.5KW hydraulic power pack. It can be supplied with various voltage motors, typically 440 or 660V. It produces 15 litres/min at 140 BAR. The motor housing is compensated separately from the hydraulic pump to lessen the possibility of water contamination.

#### Specification:

<b>Dimensions</b>	<b>Length</b>	<b>422mm</b>
	<b>Diameter</b>	<b>177mm</b>
<b>Weight</b>	<b>Weight in air</b>	<b>23.0Kg</b>
	<b>Weight in water</b>	<b>15.0Kg</b>
<b>Power</b>	<b>Input</b>	<b>3 phase 50/60Hz</b>
		<b>4.5KW (Nom.)</b>
<b>Output</b>		<b>140BAR at 15L/min (Typ.)</b>
<b>Construction</b>	<b>HE 30 aluminium</b>	
	<b>Hard Black Anodised</b>	

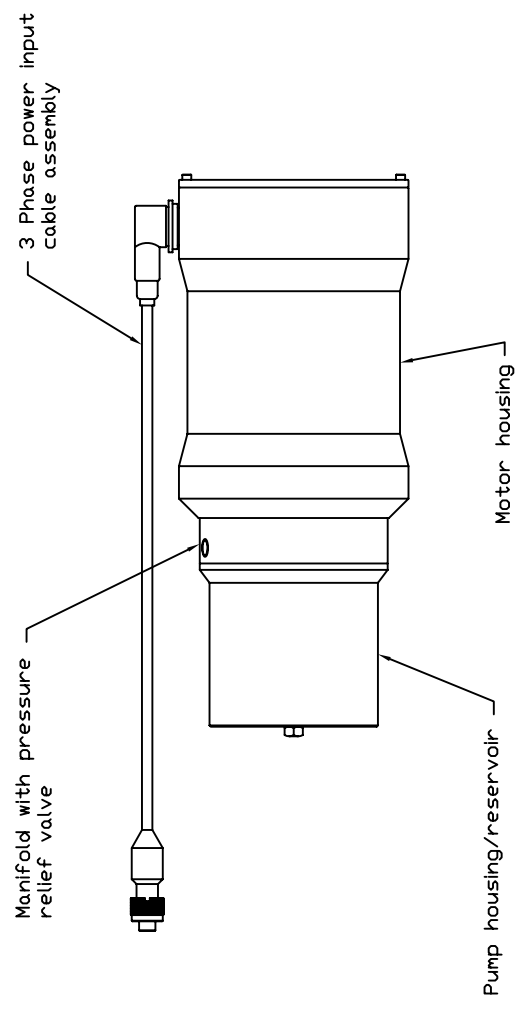
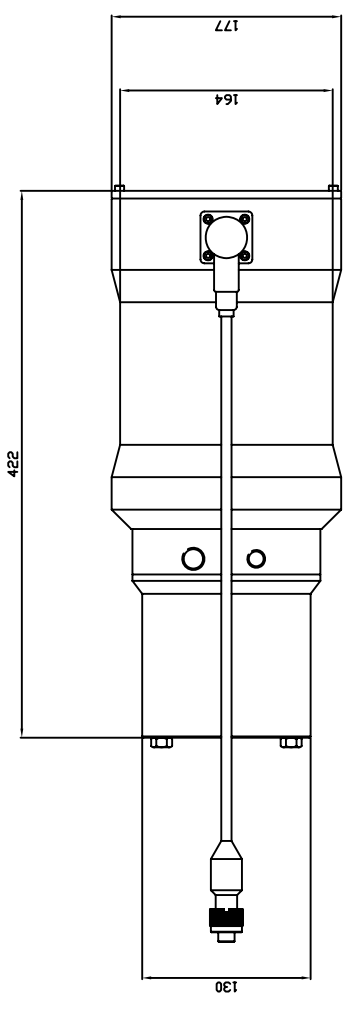

**SPECIFICATION**

Input: Voltage: 440 DR 660 Volt 3-Phase  
 Power: 4.5kW (nom)

Output: Pressure: 140 bar (Nom)  
 210 bar (Max)  
 Flow: 15 L/min

Ports: 1/4" NPT Pressure  
 3/8" NPT Return  
 1/2" NPT Compensation

Dimensions: Length: 422mm  
 Diameter: 177mm

Weight: In air: 23.0kg  
 In water: 15.0kg

Materials: Aluminium alloy 6082-T6 (HE30)  
 Hard black anodized

Designed by J0	Checked by	Approved by -	File name HLK 9015-A Section GA	Date 03/01/07	Scale 1:3
Hydro-Lek Limited Unit 4, Veller Drive, Hogwood Lane Industrial Estate, Finchampstead, Berks, RG40 4GZ. Tel: 0118 9736903			POWER PACK - 3ph 4.5kW MOTOR		
			HLK 90150		Sheet A3
			Edition A		8