

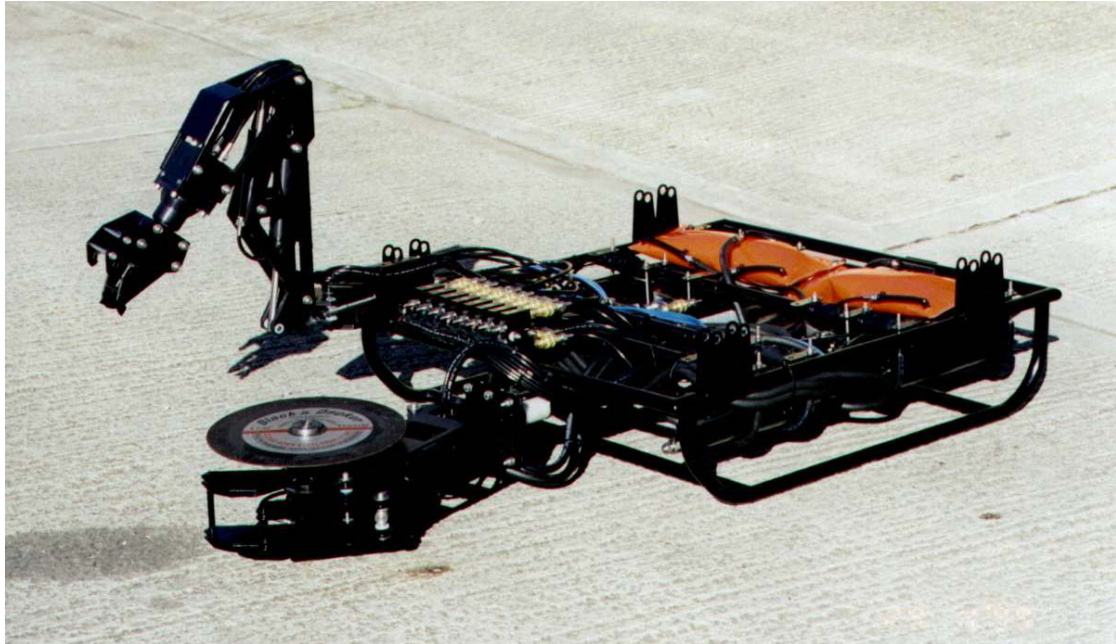

# HYDRO-LEK

## REMOTE HANDLING SPECIALISTS



### HLK-8100 Series Tool Skids:

Hydro-Lek offer a turnkey tool skid package service and can tailor any work tool skid to fit most ROV's. The company uses many of its standard components to integrate a bolt on/off sub-structure to turn a simple observation ROV to a specific work task craft, capable of competing against existing larger work class vehicles.

Typical specification for Sea Surveyor, fitted with a cutter and manipulator:

<b>Dimensions</b>	<b>Length</b>	<b>1600mm</b>
	<b>Height</b>	<b>750mm</b>
	<b>Depth</b>	<b>210mm</b>
	<b>Width</b>	<b>830mm</b>
<b>Features</b>	<b>3" Rope/cable cutter</b>	
	<b>5 Function manipulator</b>	
	<b>3 Phase power pack</b>	
	<b>Single phase control pack</b>	
	<b>8 x Bi-directional flow valves</b>	
	<b>8 x Pilot check blocks</b>	
	<b>1 x Control telemetry pod</b>	
<b>Power requirement</b>		<b>415 - 520V 3 phase AC</b>
<b>Weight</b>	<b>Weight in air</b>	<b>75Kg</b>
	<b>Weight in water</b>	<b>61Kg</b>
<b>Construction</b>	<b>316 SS</b>	
	<b>HE 30 Hard anodised aluminium</b>	

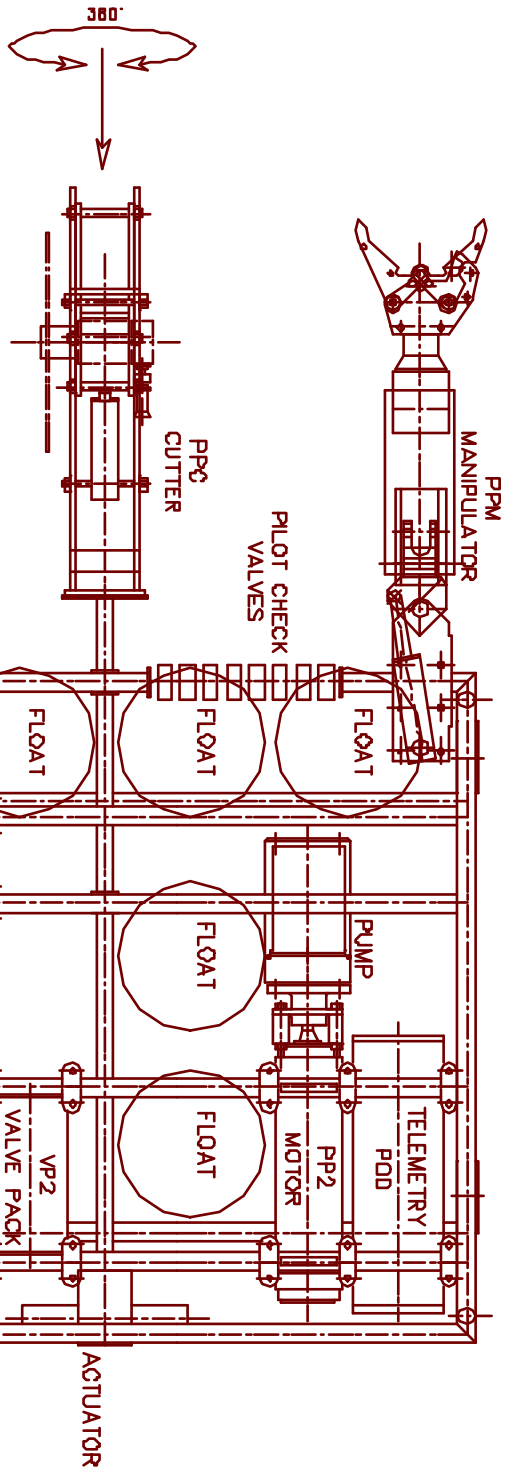
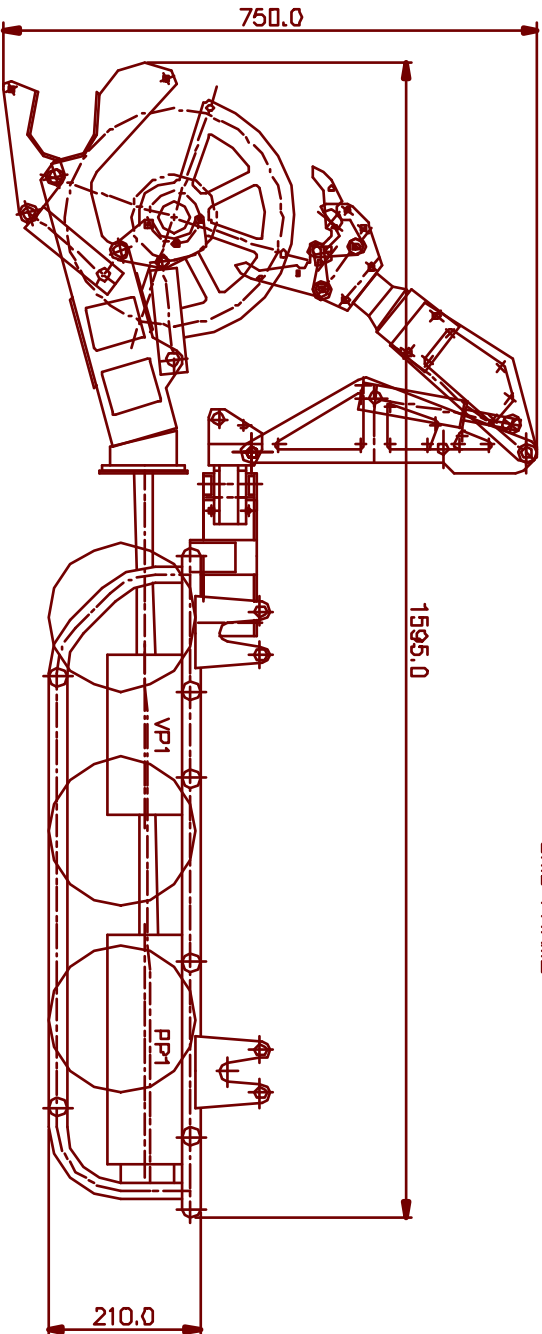
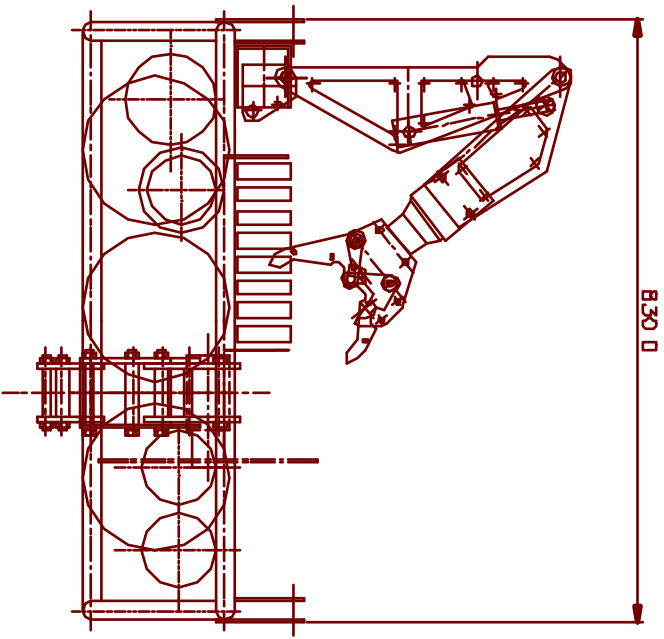

**SPECIFICATION**

POWER INPUT 415 - 520 V 3 PHASE AC  
 WEIGHT IN AIR 75 Kg  
 WEIGHT IN WATER 61 Kg  
 MATERIALS - 316 S.S.  
 HE 30 HARD ANODISED ALUMINIUM

HYDRO-LEK LTD.		COMPONENT LAYOUT IN SKID FRAME FOR SURVEYOR VEHICLE	
ISS DATE: -		MAT: -	
CHKD BY: -	REV NO: -	DRG NDE: -	CMR 8150/DATA
DRAWN BY: - JW 3D/8/99		C.M. INNOVATIONS LTD.	