

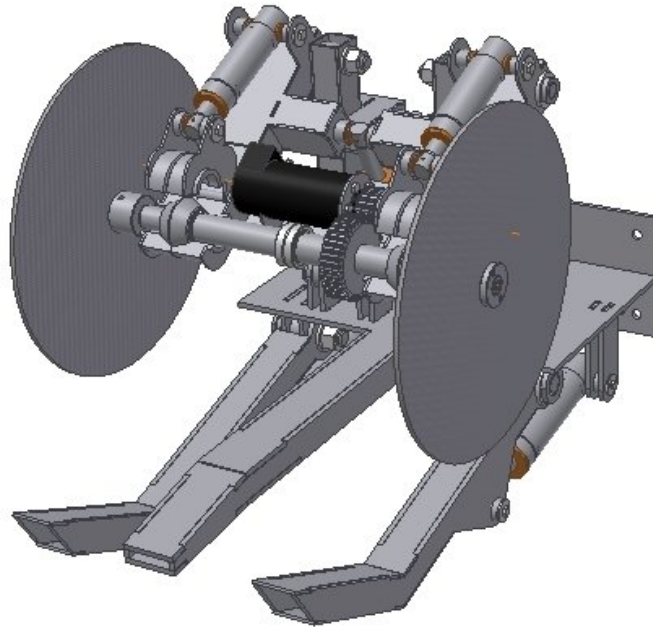

HYDRO-LEK

REMOTE HANDLING SPECIALISTS



HLK-SRT-33300 Tool:

The HLK-SRT-33300 is a purpose designed Cutter / Grab tool which can be deployed into waste storage ponds or chambers to cut and recover pipes, cables, scaffolding, trunking and general waste with diameters up to 150mm. Two articulated arms with a pair of cutting discs set at 420mm apart grind through the grabbed items, which can then be deposited into containers for safe disposal. The cutter discs can be remotely changed out using a simple manipulator and containerised for disposal. The tool, which is within 500 x 500 x 1000mm in size, can also be ejected remotely for disposal in a container

Specification:

Dimensions

Length	885mm
Height (Stowed)	450mm
Width	460mm

Capacities

Jaw opening	150mm
Cutter discs	406mm (16")
Max working pressure	210 bar
Weight	60Kg

Construction

316 Stainless Steel, Epoxy hard coated

Ports

1/8NPT / 3/8BSP

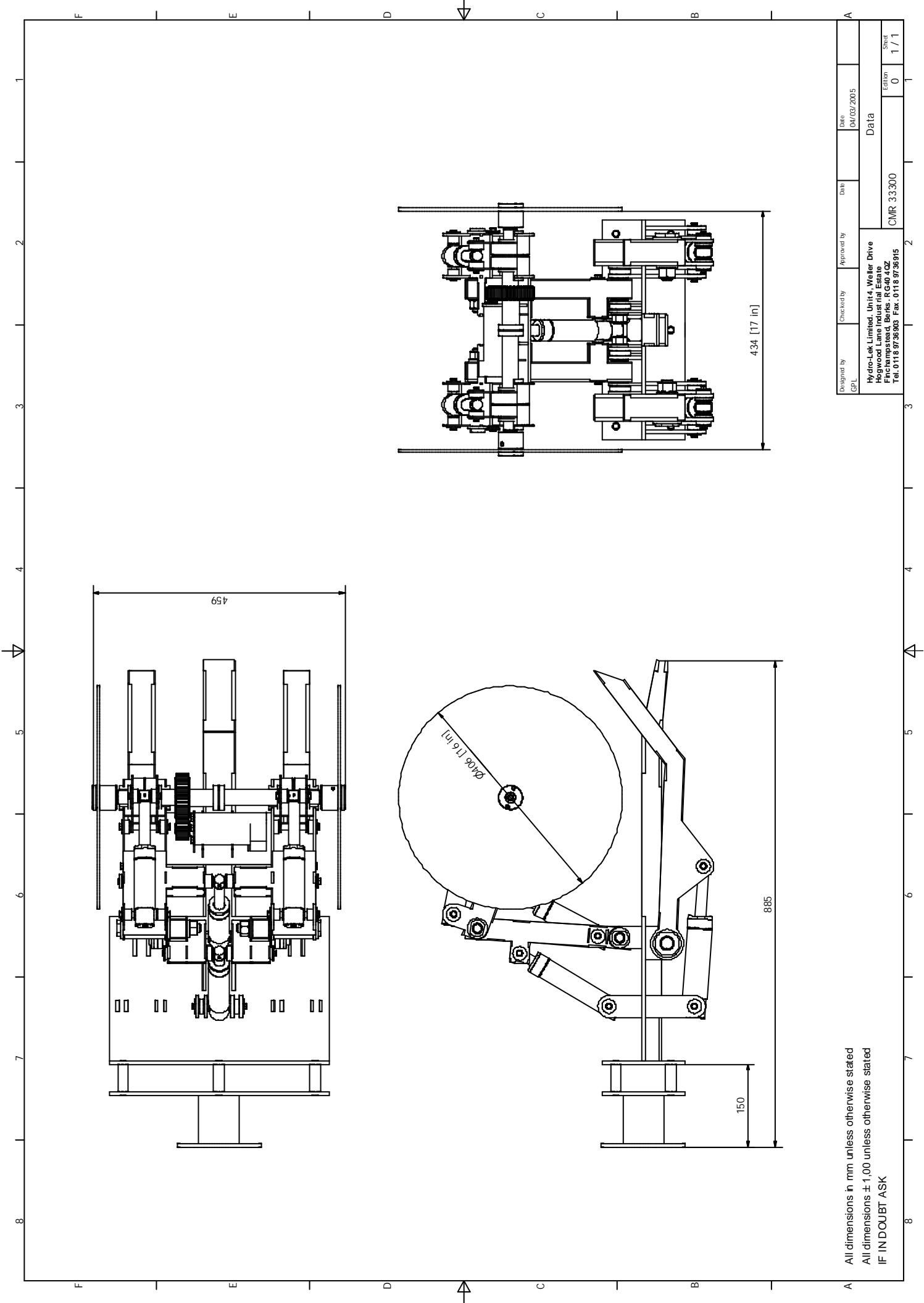

Designed by GPL	Checked by	Approved by	Date 04/03/2005	Date
Hydro-Lek Limited, Unit 4, Weller Drive Hogwood Lane Industrial Estate Frinchampstead, Berks. RG40 4DZ Tel. 0118 9735903 Fax. 0118 9736915			Data	
CNIR 33300			Edition 0	Sheet 1 / 1

All dimensions in mm unless otherwise stated
 All dimensions ± 1.00 unless otherwise stated
 IF IN DOUBT ASK