

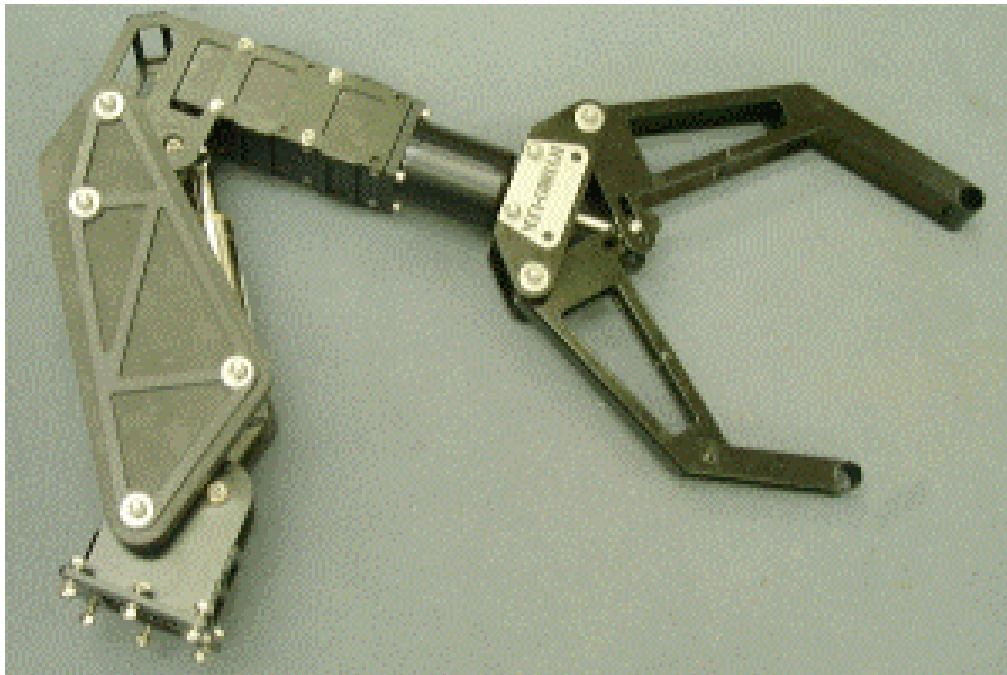

INNOVATIVE DESIGN ENGINEERING



HLK-HD 2040 Heavy Duty Grabber

A heavy duty grabber which will grab pipe up to 320 mm in diameter. Fitted with a continuous rotate which allows clockwise and anti clockwise rotation, with a torque of 35 NM. Constructed from 316 SS and HE30 aluminium. The unit shown is fitted to an HD5 manipulator.

Specification:

Dimensions	Length	649 mm
	Height	405 mm
	Width	91 mm
Capacities	Jaw rotate	Continuous
	Torque at 140 bar (across motor ports)	36 Nm
	Jaw open/close	320 - 0 mm
Weight	Weight in air	12 kg
	Weight in water	10 kg
Construction		316 Stainless Steel
		HE 30 Aluminium
Max working pressure		210 BAR
Ports		7/16 SAE

Hydro-Lek Ltd. Unit 4 Weller Drive Hogwood Lane Ind. Estate Finchampstead Berks RG40 4QZ

Telephone: +44(0) 1189 736903 Fax: +44(0) 1189 736915

Web Site <http://www.hydro-lek.com> Email: enquiries@hydro-lek.com

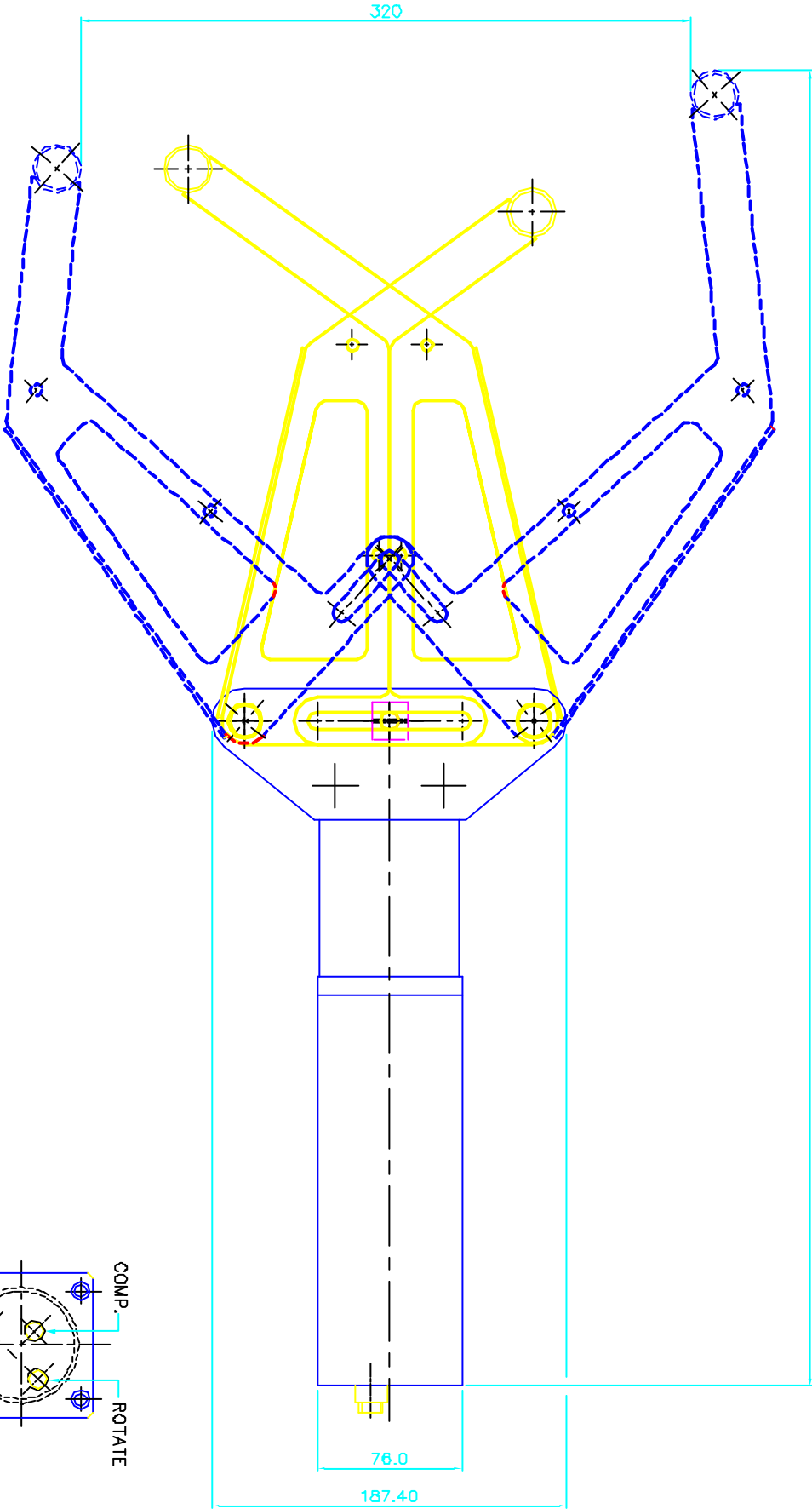

SPECIFICATION :-

JAW ROTATE
 JAW OPEN / CLOSE
 TORQUE AT 140 BAR
 WEIGHT IN AIR
 WEIGHT IN WATER
 MAX. WORKING PRESSURE
 PORTS
 MATERIALS:-

CONTINUOUS
 320 - 0
 50 Nm
 12.0 Kg
 10.0 Kg
 210 bar
 7/16" SAE
 HE 30 HARD ANODISED ALUMINIUM BLOCK
 316 S.S. JAWS ASSY.

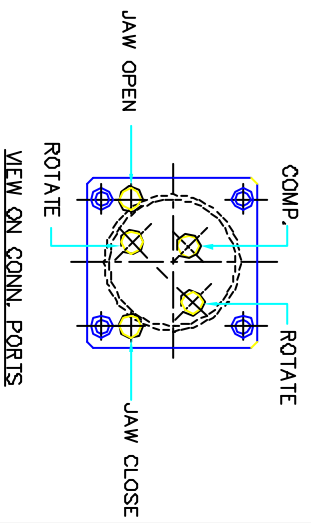

HYDRO-LEK LTD.		HLK-2040 H.D. GRABBER	
ISS. DATE:-		MAT:-	
CHKD BY:-	REV. NO:-1	DRG. NO:-	CMR 2040/DATA
DRAWN BY:- PR 4/2/02		TARGET DESIGNS	