

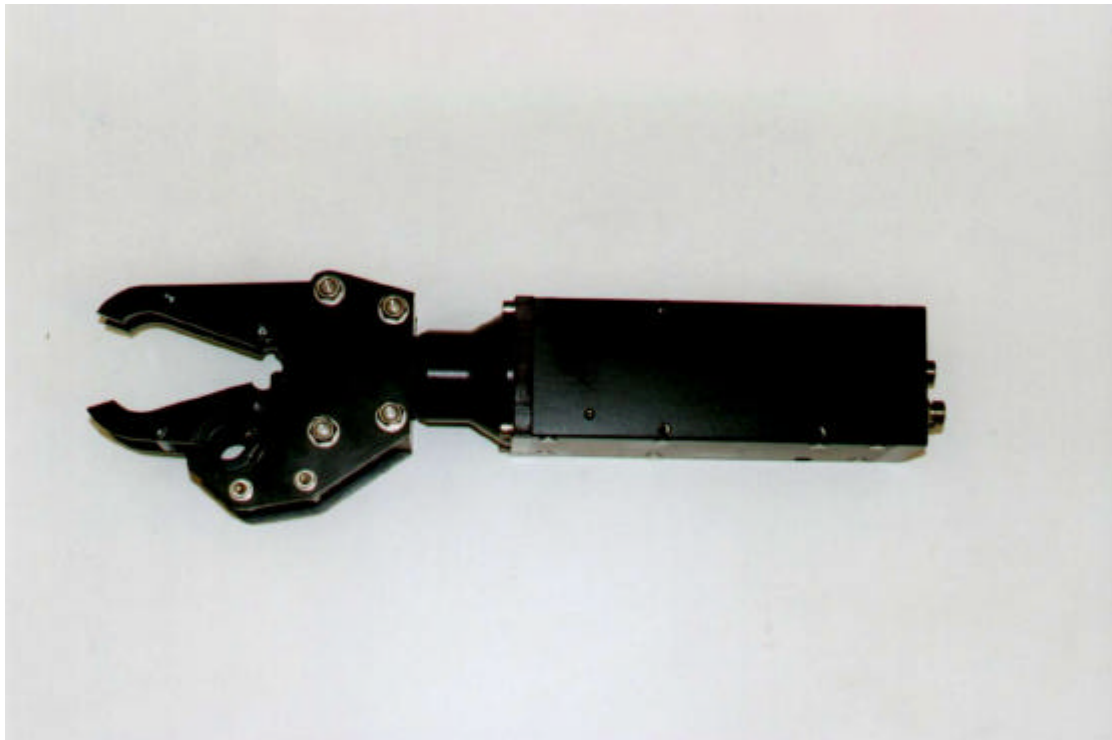

INNOVATIVE DESIGN ENGINEERING



**HLK-2020 Continuous Jaw Rotate Actuator:**

The HLK-2020 Continuous Jaw Rotate actuator is a rugged unit fitted to all HLK heavy-duty arms. Rotation is via a Geroler motor, which produces 36Nm of torque. The jaw actuator assembly also uses many of the parts found in the smaller 2010 actuator. All the control ports are accessed through the rear of the 76mm square housing, with mounting along the sides via standard HLK M6 screw inserts.

**Specification:**

<b>Dimensions</b>	<b>Length</b>	<b>428mm</b>
	<b>Height</b>	<b>130mm</b>
	<b>Width</b>	<b>85mm</b>
<b>Capacities</b>	<b>Jaw rotate</b>	<b>Continuous</b>
	<b>Torque at 140 bar (across motor ports)</b>	<b>36Nm</b>
	<b>Jaw open/close</b>	<b>154mm - 0mm</b>
<b>Weight</b>	<b>Cutter max (polypropylene rope)</b>	<b>19mm</b>
	<b>Weight in air</b>	<b>7Kg</b>
	<b>Weight in water</b>	<b>5Kg</b>
<b>Construction</b>	<b>316 SS</b>	
	<b>HE 30 Hard anodised aluminium</b>	
<b>Max working pressure</b>		<b>210 bar</b>
<b>Ports</b>		<b>7/16 SAE</b>

Hydro-Lek Ltd. Unit 4, Weller Drive Hogwood Lane Ind. Estate Finchampstead Berks U.K. RG40 4QZ

Telephone: +44(0) 1189 736903 Fax: +44(0) 1189 736915

Web Site <http://www.hydro-lek.com> Email: [enquiries@hydro-lek.com](mailto:enquiries@hydro-lek.com)

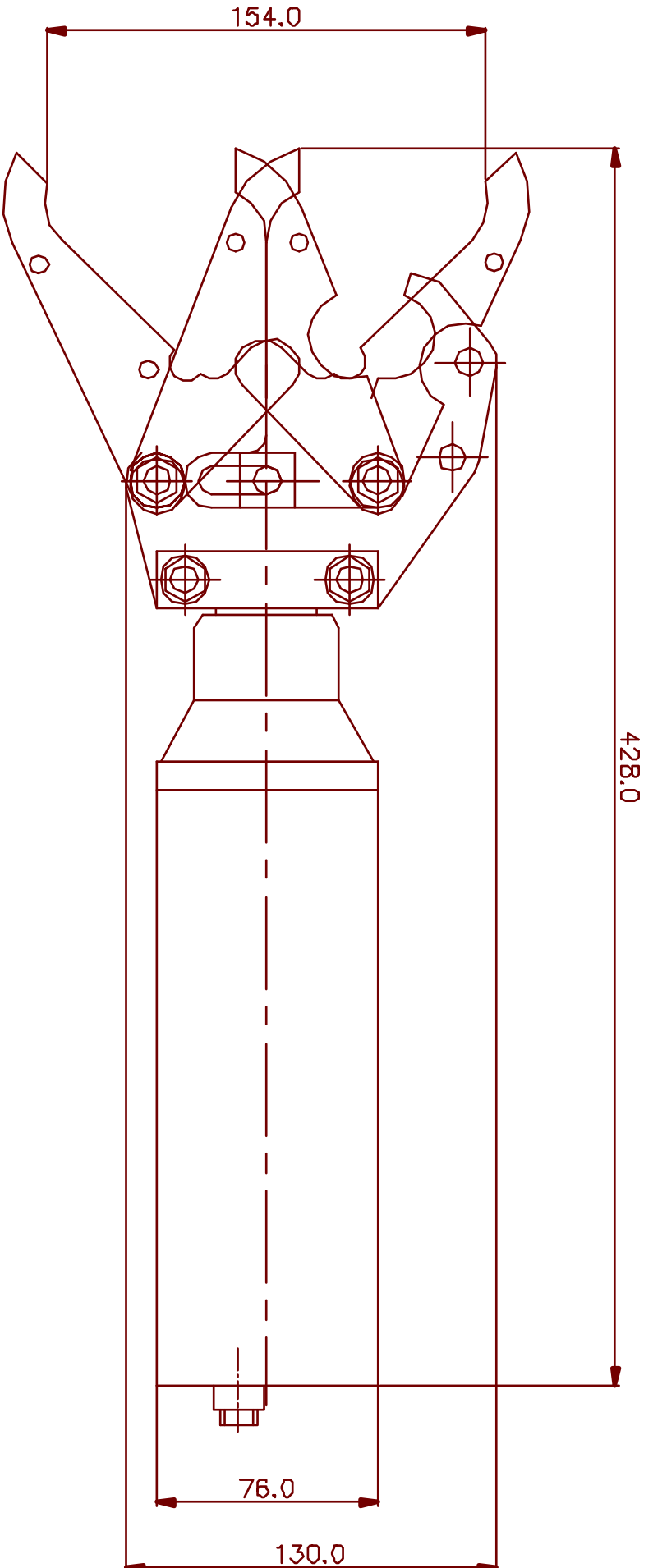

SPECIFICATION :-

JAW ROTATE  
 JAW OPEN / CLOSE  
 TORQUE AT 140 BAR  
 CUTTER MAX. (POLYPROPYLENE)  
 WEIGHT IN AIR  
 WEIGHT IN WATER  
 MAX. WORKING PRESSURE  
 PORTS  
 MATERIALS:-

CONTINUOUS  
 154 - 0  
 14 Nm  
 ø19 mm  
 7 Kg  
 5 Kg  
 210 bar  
 7/16" SAE  
 HE 30 HARD ANODISED ALUMINIUM BLOCK  
 316 S.S. JAWS ASSY.

HYDRO-LEK LTD.		HLK-2020 CONT. JAW ROTATE	
ISS. DATE:-		MAT:-	
CHKD BY:-	REV. NO:-	DRG. NO:-	CMR 2020/DATA
DRAWN BY:- JW 18/8/99		C.M. INNOVATIONS LTD.	