



HYDRO-LEK

REMOTE HANDLING SPECIALISTS



HLK-60210 Dual Port Vent valve:

The HLK-60210 Dual Port Vent Valve is designed for fitting to soft tanks on submersibles and air lift devices. It incorporates a unique dual supply piston drive which enables the vent valve to be operated from two different supplies. These can be either hydraulic, air or a combination of both.

Specification:

Dimensions	Height	120mm
	Max Diameter	140mm
	Fitting Hole	90mm Diameter
Weight	Weight in air	2.3Kg
	Weight in water	2.0Kg
Ports	Nominal Working Pressure	20 – 200BAR
	Pressure In & Emergency	1/4"Swagelok
Construction	316 Stainless Steel	

Specification & Dimensions subject to change without prior notification

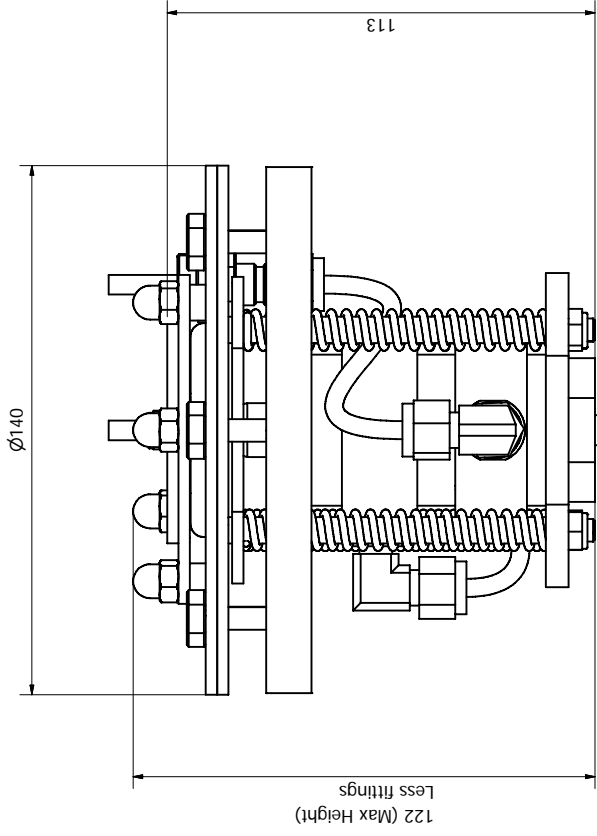

Securing Bolts with O Ring Seals
6 off

Neoprene Gasket Seal

Clamp Plate for mounting
Vent Valve to tank

Depth required inside tank

Ø92

Mounting Hole Diameter required in Tank

Emergency / Auxiliary Port
1/4" Swagelok Fitting

Main Port
1/4" Swagelok Fitting

Flow adjuster

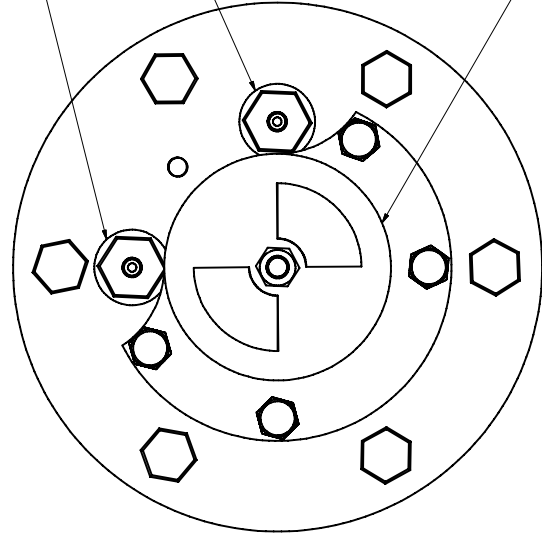

All dimensions in mm

Designed by Alan Green	Checked by	Approved by	Date	Date
HydroLeak Limited, Unit 4, Weller Drive Highwood Industrial Estate Finchampstead, Barks, RG40 4GZ Tel: 0118 9736903 Fax: 0118 9736915			21/02/2008	
HLK-60210			Dual Port Vent Valve	
Edition			Sheet	
0			1 / 1	