



HYDRO-LEK

REMOTE HANDLING SPECIALISTS



HLK-31050 Suction Pump:

The HLK-31050 Suction Pump is a Venturri device which can be driven from the HLK-31000 water jet pump or similar water supply. It is very compact and is fitted with a reversing valve to enable flows in both directions. Its output performance is dependant on the flow delivered by the separate water jet supply but typically will deliver 100 litres / minute, for a 9 litre / minute input from the pressure source, to a maximum head of 2 / 3 metres. Light weight only 1.6Kg in water.

Specification:

Dimensions	Length (less hoses)	174mm
	Width (less fittings)	75mm
	Height (less fittings)	86mm
Water Jet Input		>18 Litres/min @ >150 Bar
Output		Max Head 4 Metres Static Flow 100 Litres/min (4.5 M ³ /min)
Weight	Weight in air	2.0Kg
	Weight in water	1.6Kg
Construction	316 SS	
	HE 30 Hard anodised aluminium	

Specification:

Dimensions

Length 174mm (Less Hoses)
 Width 75mm (Less Fittings)
 Height 96mm (Less Fittings)

Water Jet Input Output

9 Litres/min @ 120 Bar
 Max Head 2.8 Metres Static
 Flow 100 Litres/min (4.5 M3/min)

Weight

in air 2.0Kg
 in water 1.6Kg

Construction

316 SS
 HE 30 Hard anodised aluminium

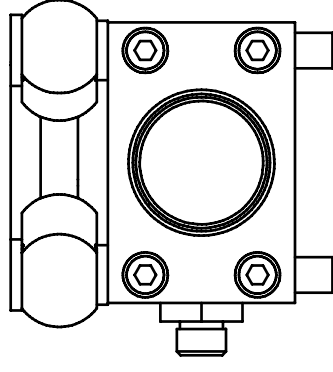
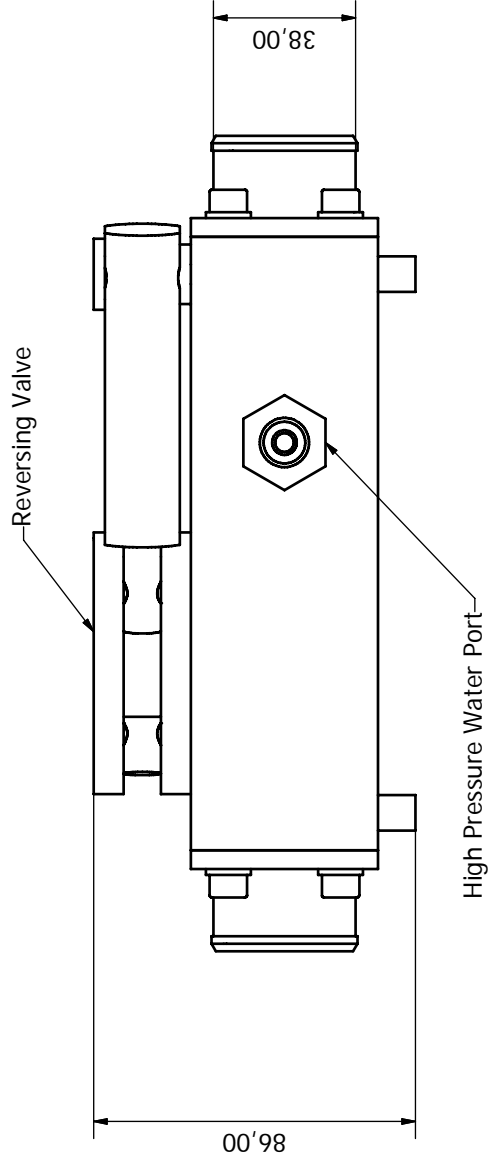
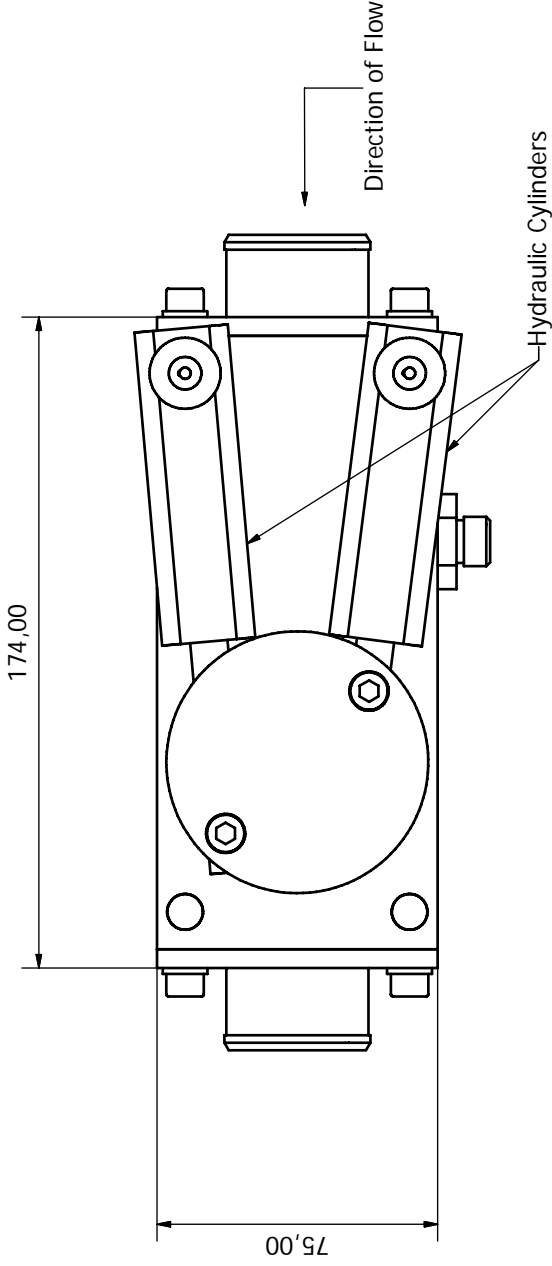

Designed by Alan Green	Checked by	Approved by	Date 31/03/2008
Hydro-Lek Limited, Unit 4, Weller Drive Hogwood Lane Industrial Estate Finchampstead, Berks. RG40 4QZ Tel: 0118 9736903 Fax: 0118 9736915			HILK-31050
Venturri			Edition 0
			Sheet 1 / 1